

VARÈSE
Setup Guide

VARÈSE

Welcome

When an artist creates music, they build a world: a universe of details that intertwine and collide to create something unique. Behind each of these fine details is a story, a thought, a feeling or an idea, and it's only when we can hear them all that we can truly immerse ourselves in a performance and see the world that an artist wants us to see.

Thank you for choosing the Varèse music system.

Document information

Published on: 27/11/2024

Document ID: DCS421681 - Rev 1.10

Copyright

Copyright © 2024 Data Conversion Systems Ltd. All Rights Reserved.

Information contained in this manual is subject to change without notice, and whilst it is checked for accuracy, no liabilities can be accepted for errors.

dCS is Data Conversion Systems Ltd. Company registered in England No. 2072115.

Other product and company names may be trademarks or registered trademarks of other companies, and are the property of their owners. They are used only for explanation, without intent to infringe.

Intended purpose

This document provides set up and configuration and compliance information for the Varèse music system, which includes the Core, User Interface, left Mono DAC, right Mono DAC, Clock, and Remote Control.

Conventions in this document

This document uses the following safety notices and tips:



WARNING

Indicates a hazardous situation which, if not avoided, could result in death or serious injury.



CAUTION

Indicates a hazardous situation which, if not avoided, could result in moderate injury, damage the product, or lead to loss of data.

NOTICE

Indicates an important situation which, if not avoided, may seriously impair operations.



Additional information relating to the current section.

Contents

Welcome	2
Introducing Varèse	4
What's in the box	5
Varèse Core, User Interface, Remote Control, and ACTUS cables	5
Varèse Mono DAC (left)	6
Varèse Mono DAC (right)	7
Varèse Clock	8
Where to place the Varèse units	9
Overview	10
About ACTUS cables	10
Core overview	10
User Interface overview	13
Remote Control overview	14
Left Mono DAC overview	16
Right Mono DAC overview	17
Clock overview	18
Status lights	19
Setting up	20
Using ACTUS cables	20
Connecting the Core	20
Connecting the Mono DACs to amplifiers	22
Connecting the Digital I/O Module	24
Connecting power and switching on	25
Connecting to your network	25
Maintenance	27
Charging the Remote Control's battery	27
Cleaning the unit	27
Replacing a blown mains fuse	28
Specifications	30
Core specifications	30
User Interface specifications	31
Mono DAC specifications	31
Clock specifications	32
Remote Control specifications	32
Help and support	33

Introducing Varèse

Varèse is designed to be easily and quickly set up so you can enjoy your music.

You can control the Varèse music system in three ways that work seamlessly together and guarantee the best user experience, regardless of how you interact with your music.

dCS Mosaic ACTUS

Use the application when you want full control over your system directly from your favourite mobile device.

User Interface display

Use the touchscreen on the display when you are close to the system and want to quickly change a track and adjust system settings.

Varèse Remote Control

Use the Remote Control when you want to be away from all bright displays but still have access to the basic controls of the system.

This document covers the setup of the whole Varèse music system, which includes the following components that deliver the best possible listening experience:

- Core
- User Interface
- Remote Control
- Left Mono DAC
- Right Mono DAC
- Clock
- ACTUS cables

What's in the box

If an item is missing from a box, contact your fulfilment centre.



We recommend that you keep the original packaging of all units. If you need to order replacement packaging, contact your fulfilment centre.

Varèse Core, User Interface, Remote Control, and ACTUS cables

Box 1

The box contains the following items:

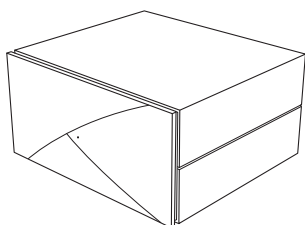

Varèse Core

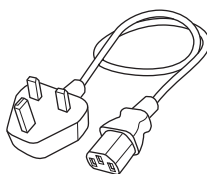

Power cable (2 m)

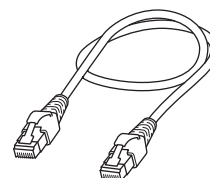

Ethernet cable (2 m)



Welcome letter

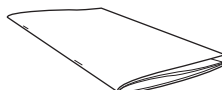

Safety and compliance guide

Box 2

The box contains the following items:

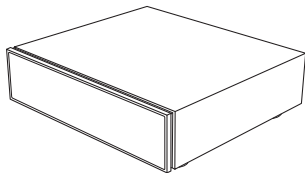

Varèse User Interface



Antenna for User Interface

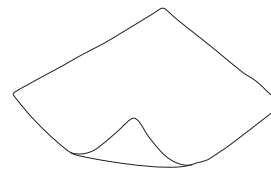

Display cleaning cloth

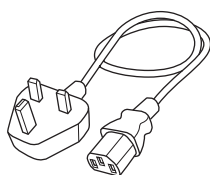

Power cable (2 m)



Welcome letter



Safety and compliance guide

Box 3

The box contains the following items:

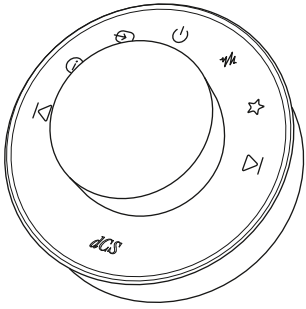

Varèse Remote Control

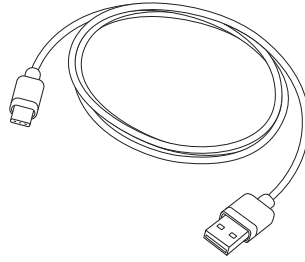

USB-C cable (1 m)

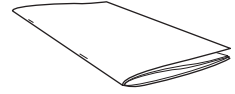

Safety and compliance guide

Box 4

The box contains the following items:

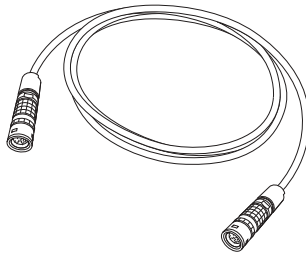

ACTUS cable

1.5 m (standard), other lengths
available

Varèse Mono DAC (left)

Box 1

The box contains the following items:

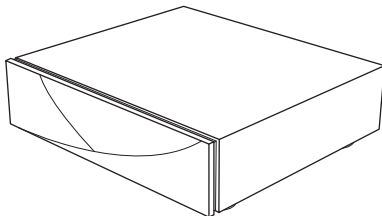

Varèse left Mono DAC

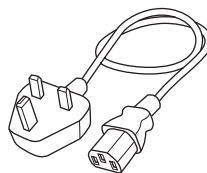

Power cable (2 m)

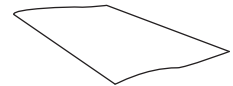

Welcome letter



Safety and compliance guide

Box 2

The box contains the following items:

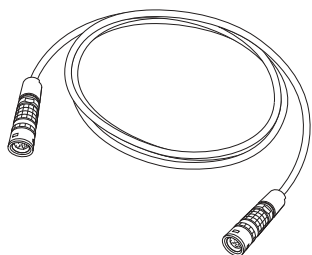

ACTUS cable

1.5 m (standard), other lengths available

Varèse Mono DAC (right)

Box 1

The box contains the following items:

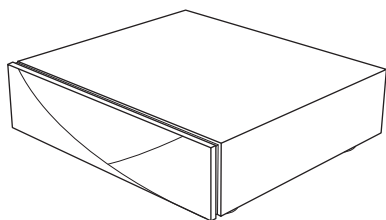

Varèse right Mono DAC

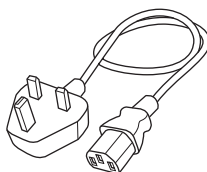

Power cable (2 m)



Welcome letter

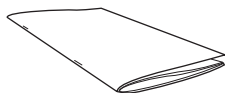

Safety and compliance guide

Box 2

The box contains the following items:

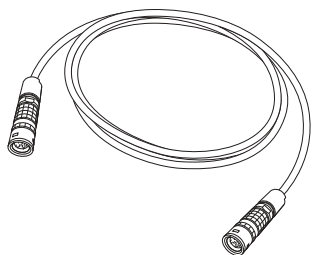

ACTUS cable

1.5 m (standard), other lengths available

Varèse Clock

Box 1

The box contains the following items:

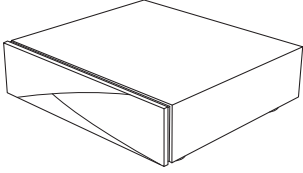

Varèse Clock

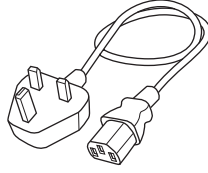

Power cable (2 m)



Welcome letter

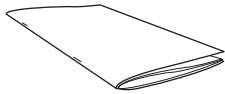

Safety and compliance guide

Box 2

The box contains the following items:

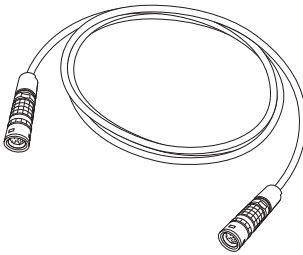

ACTUS cable

1.5 m (standard), other lengths
available

Where to place the Varèse units

The units in the Varèse range are designed to be mounted on separate shelves of a rack. Place each unit on a firm, vibration-free base, allowing convenient connection to the other parts of your system.



To prevent overheating, we recommend that you leave some space around the units to allow for ventilation.

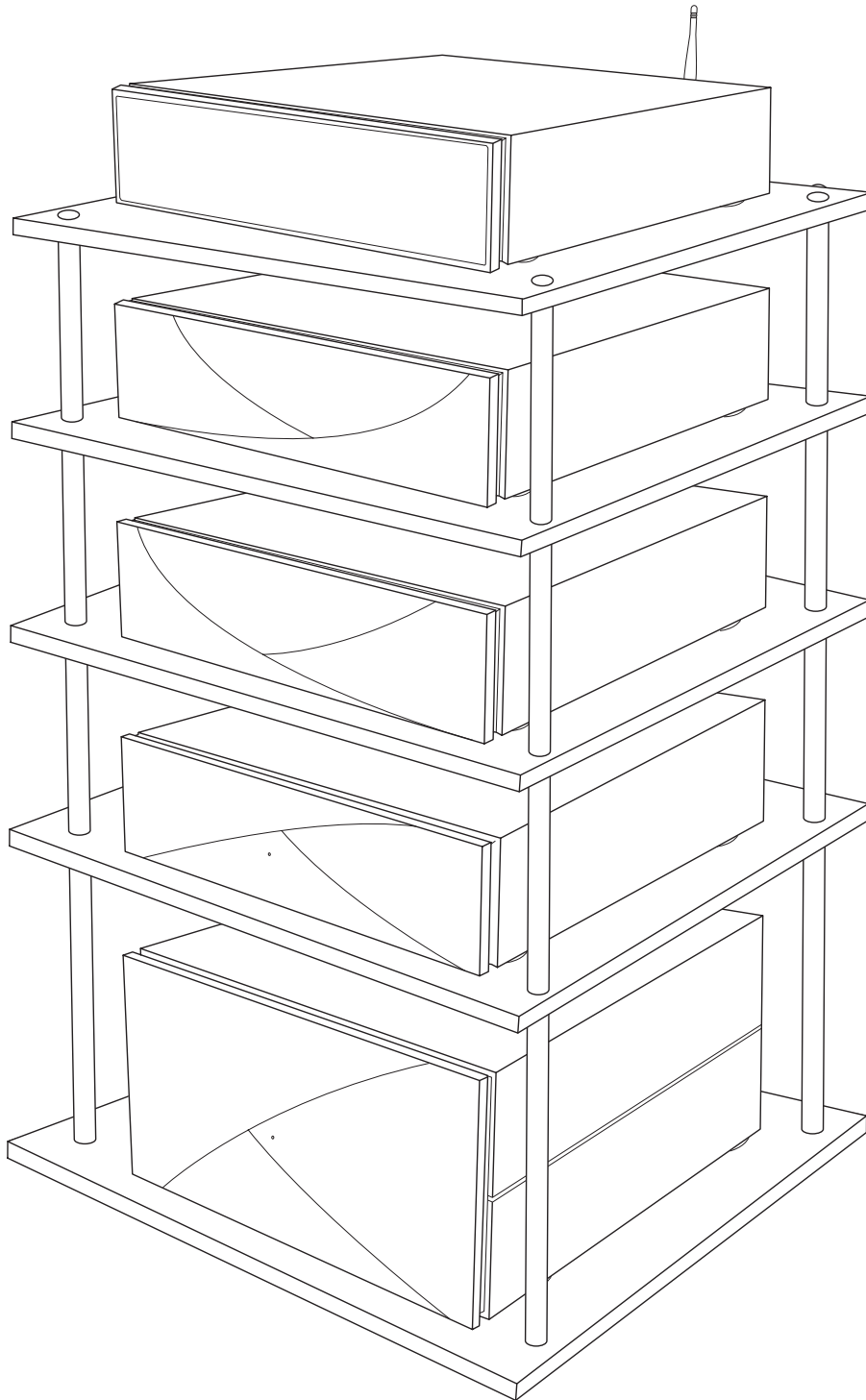

Overview

About ACTUS cables

Varèse features a bespoke interface, created by dCS to allow for ultimate audio quality and seamless control of the whole system. This interface is called ACTUS - Audio Control and Timing Unified System.

ACTUS is a combination of proprietary dCS hardware and software that enable the Varèse units to be connected using a single cable between each unit.

The interface includes asynchronous and error corrected digital audio, control signals, and a master clock signal.

Core overview

The Core is the main hub of the Varèse system. It is a modular, upgradeable unit that processes audio and connects to the internet to provide access to online music streaming services.

Front

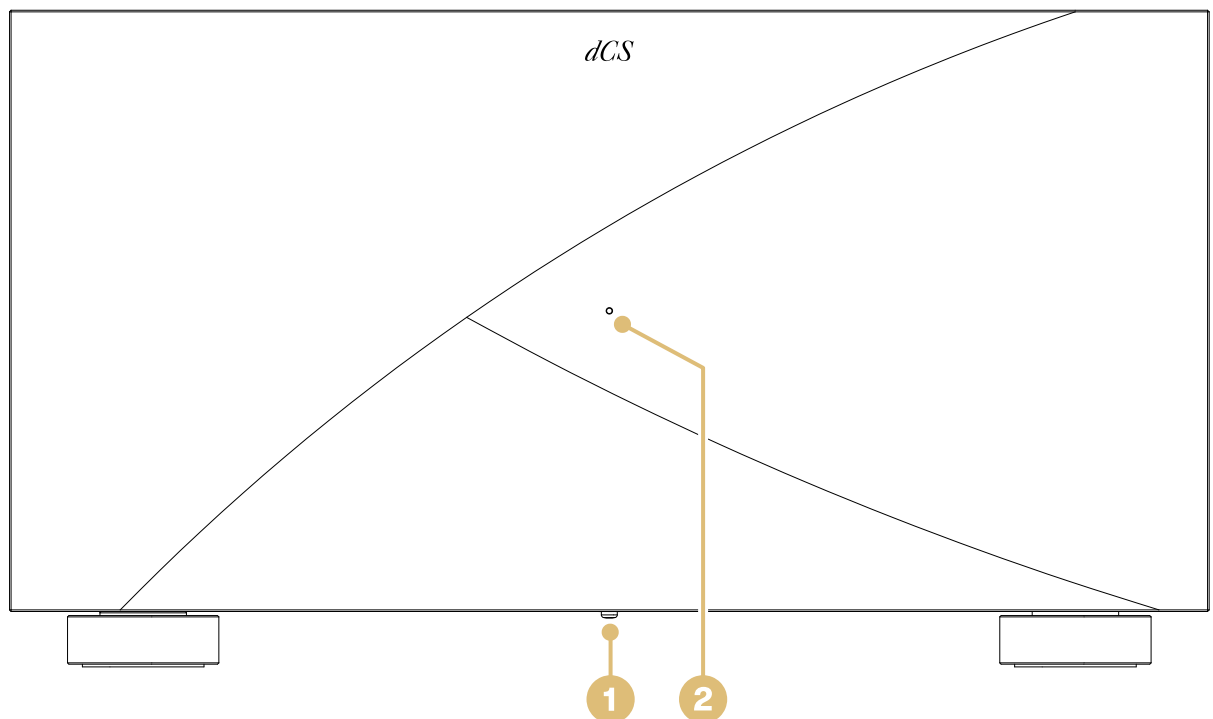

Item	Description
1 Standby button	If rest mode is activated, toggles between on, rest (short press), or sleep (long press). If rest mode is not activated, toggles between on, standby (short press), or sleep (long press).
2 Status light	Indicates the unit status by changing colour. For more information, see "Status lights" on page 19.

Rear

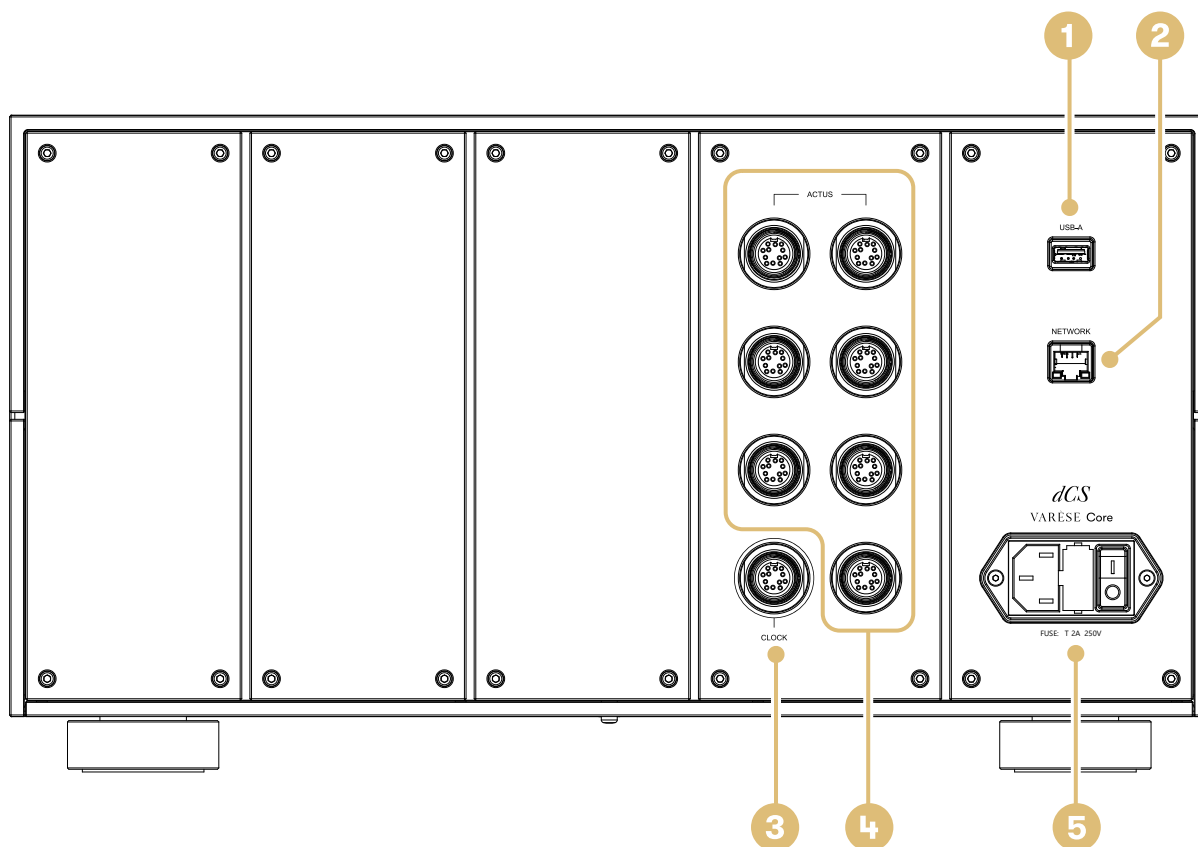

Item	Description
1 <i>USB</i>	USB-A digital input. Connects the unit to a USB flash drive or used to charge the Remote Control.
2 <i>NETWORK</i>	RJ45 network input. Connects the unit to the local network or the internet.
3 <i>ACTUS (Clock only)</i>	Connects the unit to a Varèse Clock.
4 <i>ACTUS</i>	Connects the unit to other Varèse units, except the Clock.
5 Power socket, fuse, and power switch	Powers the unit via a standard IEC320 connector, with a power switch and a fuse holder.

Optional Digital I/O Module - Rear

If requested, your Core is fitted with the Digital I/O Module. This module is used to connect other sources, such as CD transports or PCs, and features an S/PDIF output and a word clock output.

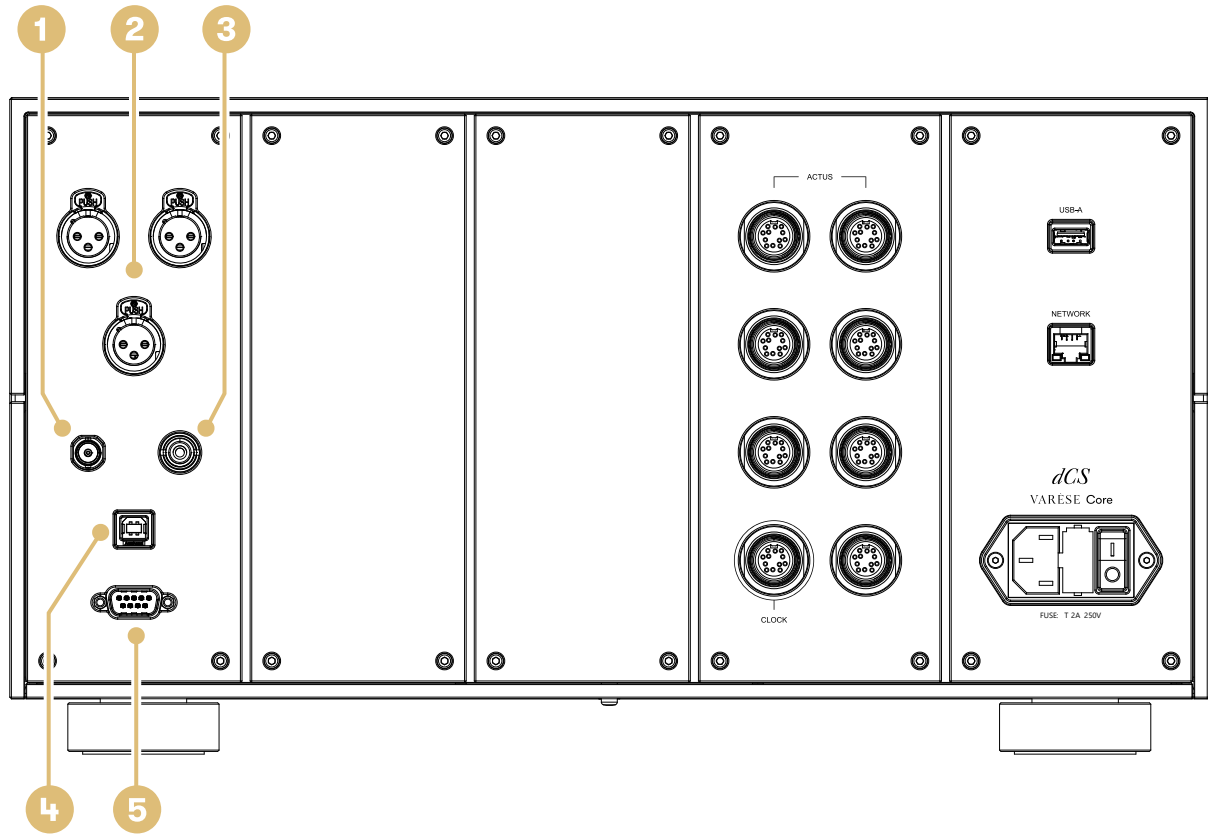

Item	Description
1	Word clock output port BNC word clock output. Connects to the clock input of a digital audio source, for example, a Rossini or Vivaldi Transport. The output frequency of this port is either 44.1k or 48k, automatically adjusted to match the base sample rate of the incoming data.
2	AES 1, 2 and 3 ports AES inputs on XLR connectors. Connects the unit to a digital source, for example, a Rossini or Vivaldi Transport. AES 1 and 2 automatically detect incoming Dual AES signals to work as a Dual AES pair.
3	S/PDIF output port The S/PDIF output on an RCA connector. Outputs ≤ 192k.
4	USB-B port Connects the Core to a PC or Mac.
5	RS232 port Connects to the RS232 communication port of a Rossini or Vivaldi Transport with a null modem cable.

User Interface overview

The User Interface controls and displays music playback, settings, and user feedback. With the User Interface, you can connect to AirPlay and Google Cast services. This unit also seamlessly works with other Varèse controllers – the dCS Mosaic ACTUS app and Remote Control.

Front

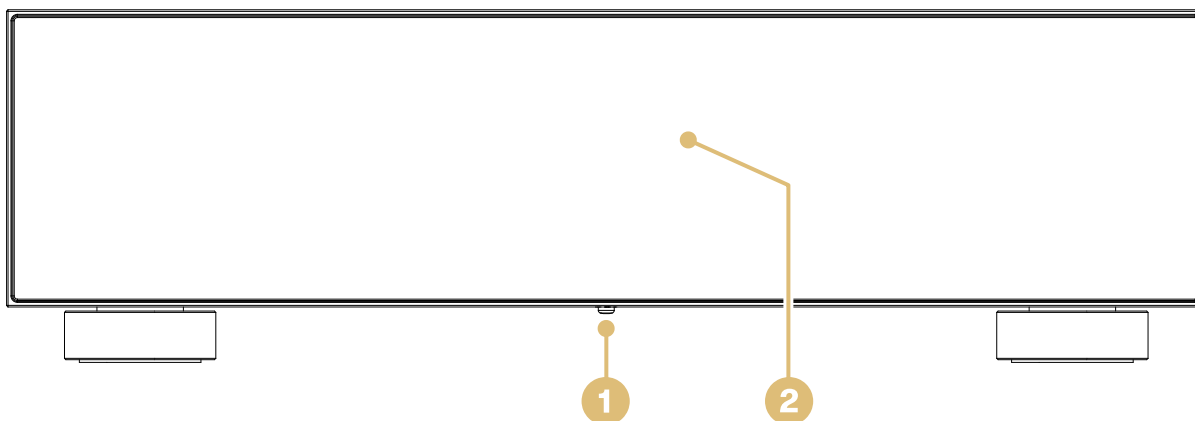

Item	Description
1 Standby button	If rest mode is activated, toggles between on, rest (short press), or sleep (long press). If rest mode is not activated, toggles between on, standby (short press), or sleep (long press).
2 Touchscreen	Controls the unit and displays playback information.

Rear

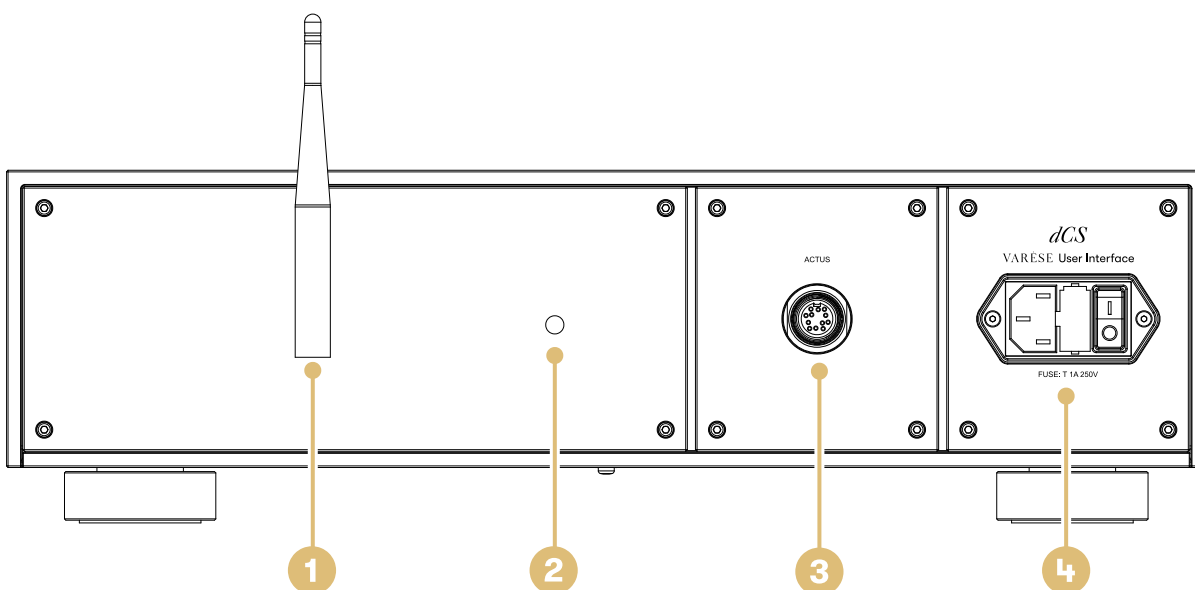

Item	Description
1 Antenna	Receives signals from the Remote Control. 💡 You need to attach the antenna to the rear of the User Interface.
2 Status light	Indicates the unit status by changing colour. ▶ For more information, see "Status lights" on page 19.
3 ACTUS	Connects the unit to the Core.
4 Power socket, fuse, and power switch	Powers the unit via a standard IEC320 connector, with a power switch and a fuse holder.

Remote Control overview

The Remote Control wirelessly connects to the User Interface and provides basic control of the Varèse system.

💡 To comply with IATA lithium battery shipping regulations, the Remote Control's battery is supplied partially charged. Charge the battery fully before use.

▶ For more information, see "Charging the Remote Control's battery" on page 27.

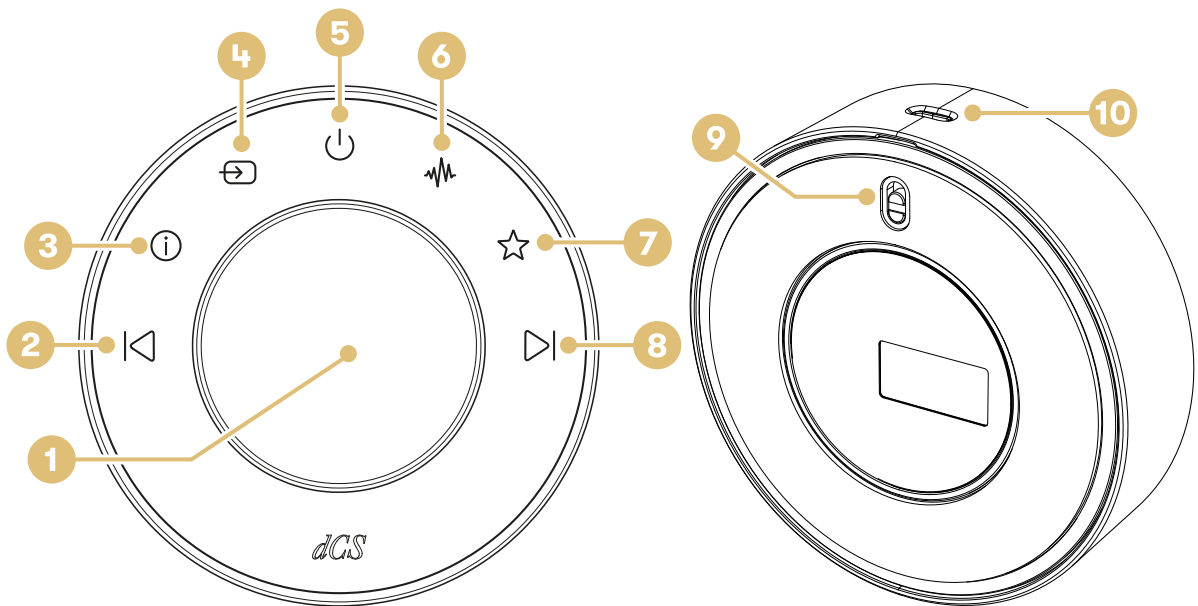

Item	Description
1 Volume control	<ul style="list-style-type: none"> • If turned, increases or decreases volume. • If pushed, toggles between play and pause. • If pushed while listening to a radio station, toggles between mute and unmute.
2 Previous	Selects the previous available track.
3 Info	Changes the information shown on the User Interface touchscreen.

Item	Description
4	Source Selects the next available audio source.
5	Power If rest mode is activated, toggles between on, rest, or sleep. If rest mode is not activated, toggles between on, standby, or sleep.
6	Signal path preset Changes to the next signal path preset.
7	Shortcut button Assignable button
8	Next Selects the next available track.
9	Power switch Switches on the Remote Control.
10	USB-C charging port Connects the Remote Control to an external power source to charge the battery.

Remote Control status LEDs

When the Remote Control is turned on, the status LEDs provide information about the state of the Remote Control.

Status	Icons	Colour / action
Off	All	Off
On (not connected)	Power LED	Blue flashing
On (pairing mode)	Power LED	Blue pulsing To put the Remote Control into Bluetooth pairing mode, switch on the unit while pressing down the volume control.
On (connected)	All	White (only when in operation or activated by the proximity sensor)
Firmware update	Power LED	Magenta
Error	Power LED	Red flashing
Charging (USB power connected)	Power LED	Amber
Charged (USB power connected)	Power LED	Green

NOTICE

If the Remote Control is turned off with the mechanical switch, and the USB charging cable is connected, the Remote Control still charges, although no status LED is shown.



If the Remote Control cannot be connected to the Varèse User Interface, it can also be connected to a USB charger that can supply 1A.

Left Mono DAC overview

The Mono DAC converts a digital signal to analogue, allowing you to connect the Varèse system to pre-amps and power amps.

Front

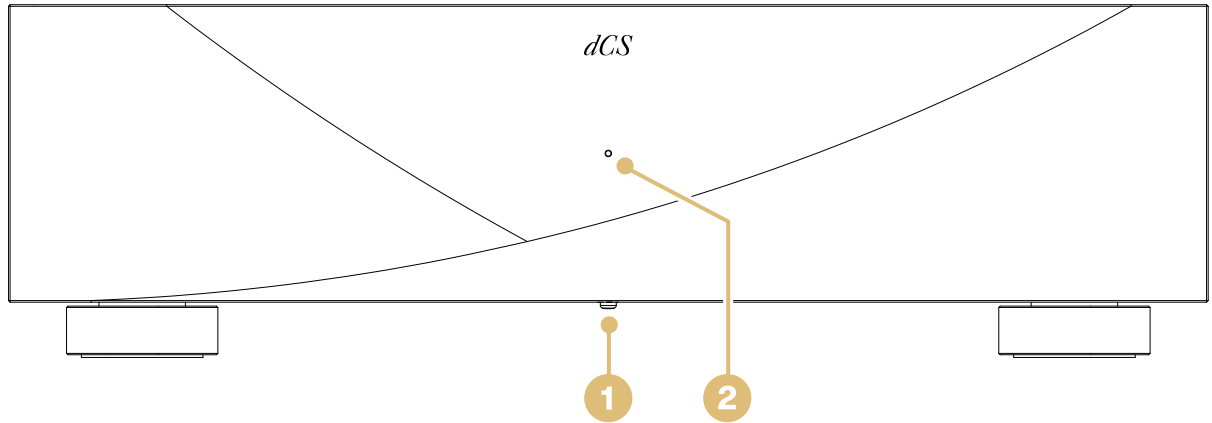

Item	Description
1 Standby button	If rest mode is activated, toggles between on, rest (short press), or sleep (long press). If rest mode is not activated, toggles between on, standby (short press), or sleep (long press).
2 Status light	Indicates the unit status by changing colour. ► For more information, see "Status lights" on page 19.

Rear

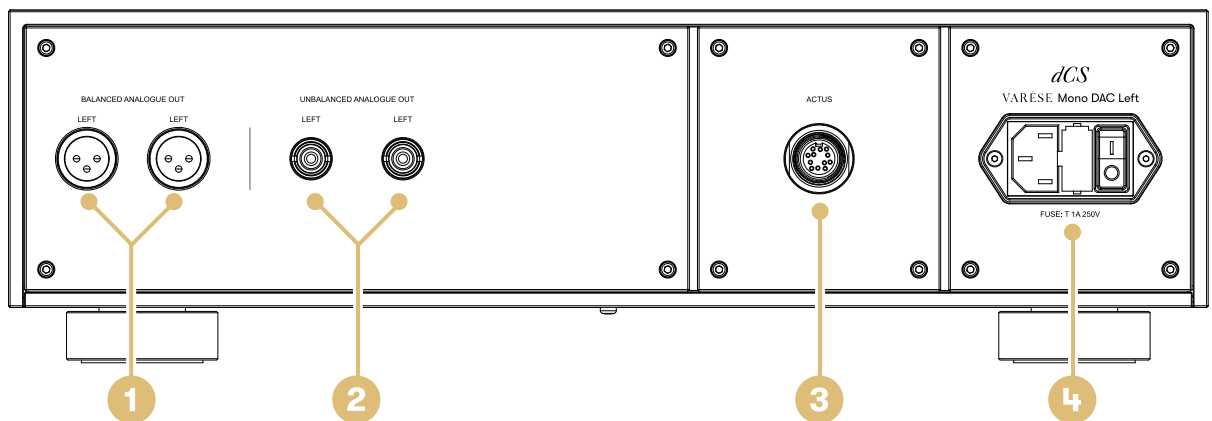

Item	Description
1 BAL. LEFT	Mono (left) balanced XLR analogue outputs. Connects the unit to an amplifier.
2 UNBAL. LEFT	Mono (left) unbalanced RCA analogue outputs. Connects the unit to an amplifier.
3 ACTUS	Connects the unit to the Core.
4 Power socket, fuse, and power switch	Powers the unit via a standard IEC320 connector, with a power switch and a fuse holder.

Right Mono DAC overview

The Mono DAC converts a digital signal to analogue, allowing you to connect the Varèse system to pre-amps and power amps.

Front

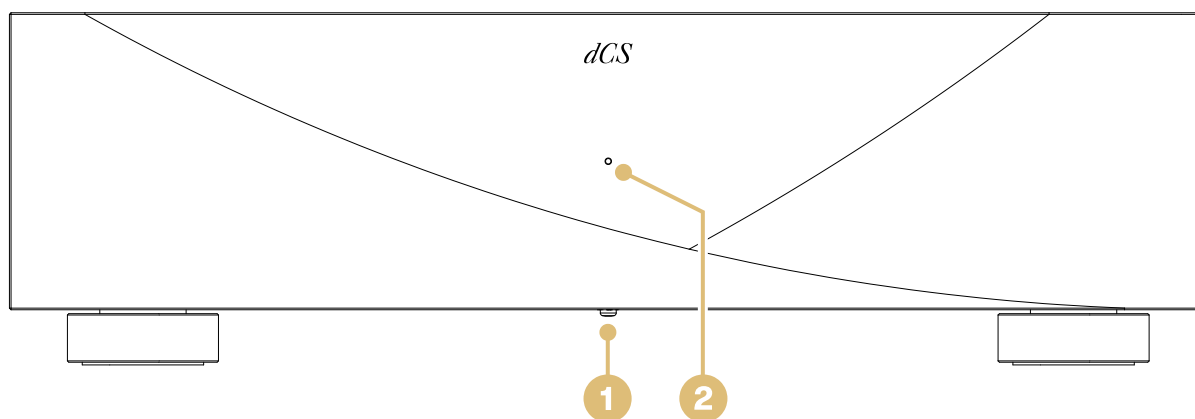

Item	Description
1 Standby button	If rest mode is activated, toggles between on, rest (short press), or sleep (long press). If rest mode is not activated, toggles between on, standby (short press), or sleep (long press).
2 Status light	Indicates the unit status by changing colour. ▶ For more information, see "Status lights" on page 19.

Rear

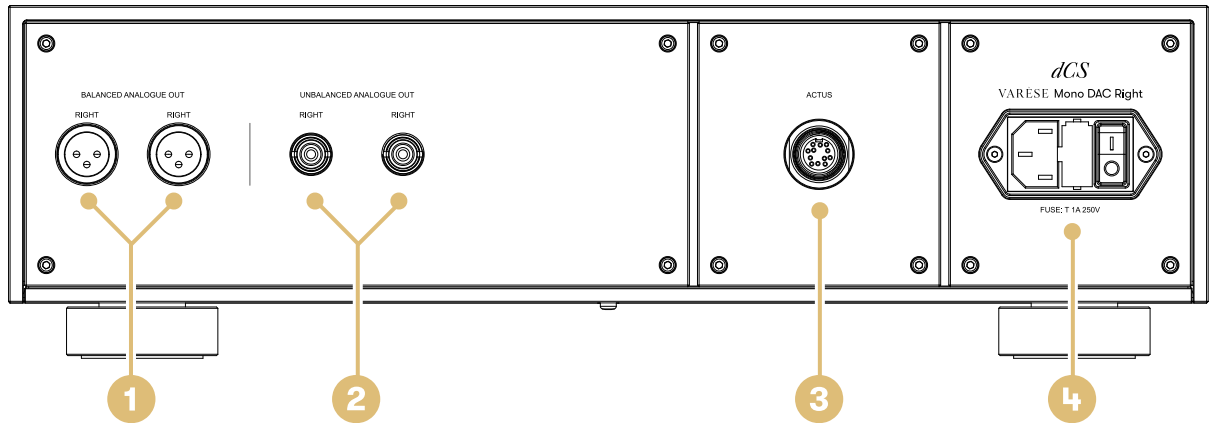

Item	Description
1 BAL. RIGHT	Mono (right) balanced XLR analogue outputs. Connects the unit to an amplifier.
2 UNBAL. RIGHT	Mono (right) unbalanced RCA analogue outputs. Connects the unit to an amplifier.
3 ACTUS	Connects the unit to the Core.
4 Power socket, fuse, and power switch	Powers the unit via a standard IEC320 connector, with a power switch and a fuse holder.

Clock overview

The Clock in the Varèse system supplements the Core and the Mono DACs to deliver increased sonic performance. The Clock provides an ultra-low jitter reference for the Varèse system to synchronise to.

Front

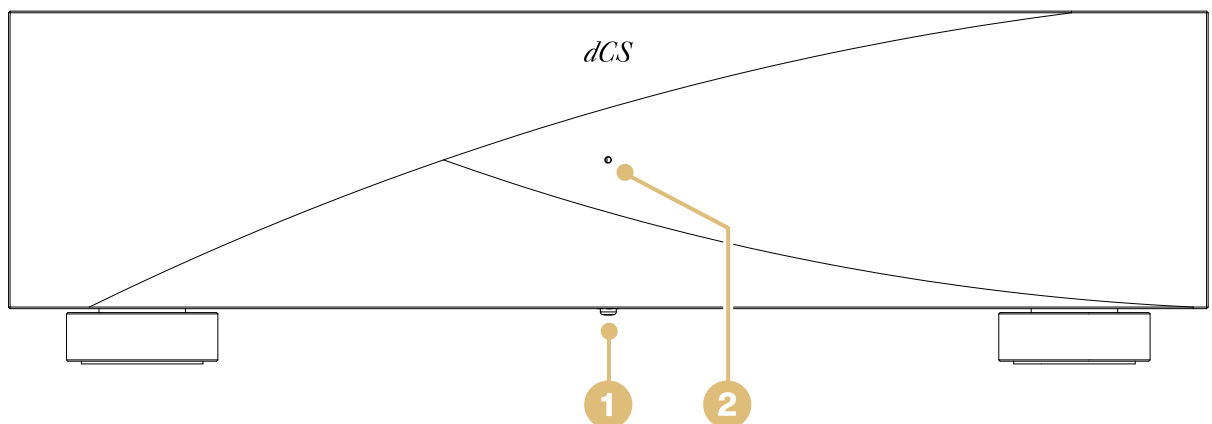

Item	Description
1 Standby button	If rest mode is activated, toggles between on, rest (short press), or sleep (long press). If rest mode is not activated, toggles between on, standby (short press), or sleep (long press).
2 Status light	Indicates the unit status by changing colour. ▶ For more information, see "Status lights" below.

Rear

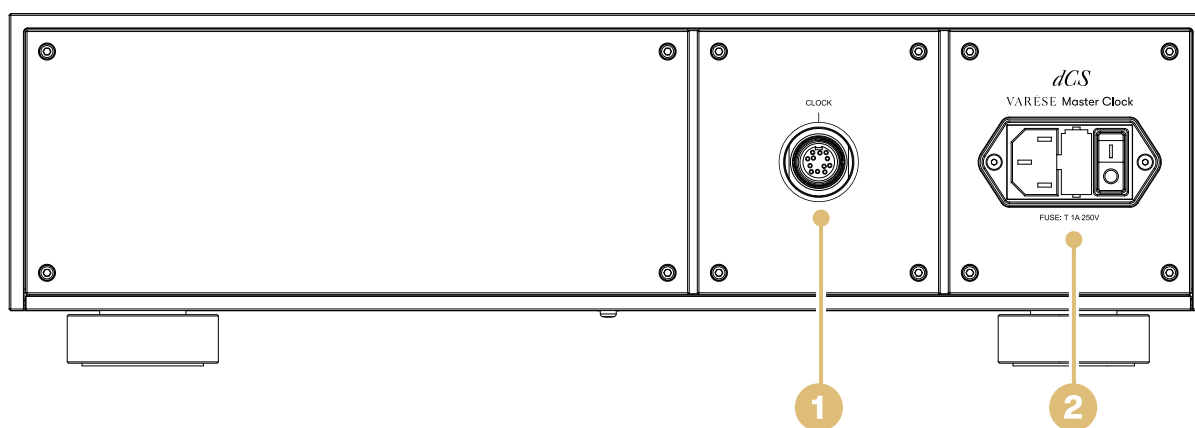

Item	Description
1 ACTUS	Connects the unit to the Core.
2 Power socket, fuse, and power switch	Powers the unit via a standard IEC320 connector, with a power switch and a fuse holder.

Status lights

Each unit has a light. The light changes colour to show the current status of the unit.

Colour	Unit status
Bright white (solid)	Active mode and connected to another Varèse unit.
Bright white (pulsing)	Active mode but not connected to another Varèse unit.
Amber	Rest mode.
Dim white	Standby mode.
Red	Sleep mode.
Magenta	Installing a firmware update.
Light off	Off.

Setting up

After you unpack, confirm the contents of all boxes, and position your Varèse products, start connecting and powering the units.



With all your Varèse units connected, you can use the dCS Mosaic ACTUS app to finish configuring your audio system.

Using ACTUS cables

Use the supplied ACTUS cables to provide a steady connection between your Varèse units.



ACTUS sockets are located at the rear of each unit.

1. Line up the indicators on the ACTUS cable connector and on the ACTUS socket at the rear of a Varèse unit.
2. Press the connector into the socket to lock the connector in place.

Disconnecting ACTUS cables

To disconnect the ACTUS cable, pull back the knurled part of the connector and pull the cable. This releases the connector from the socket.



CAUTION

Never pull the connector without using the release mechanism. This could damage both the connector and the socket.

Connecting the Core

Use the supplied ACTUS cables to connect your Varèse units to the Core.

1. Using the supplied ACTUS cables, connect the Clock-specific ACTUS socket at the rear of the Core to the ACTUS socket at the rear of the Clock.

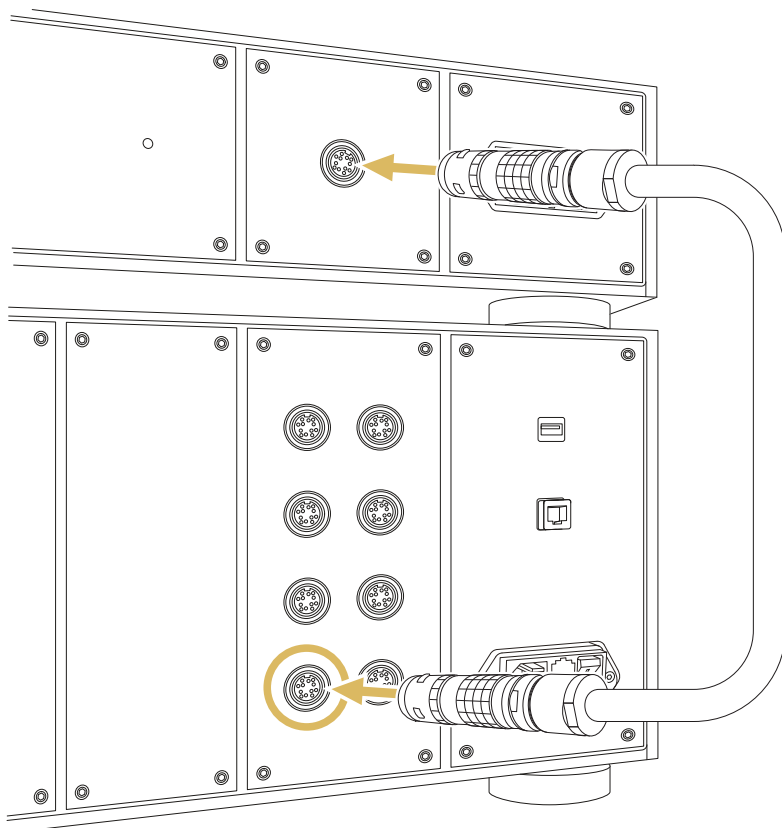

2. Using the supplied ACTUS cables, connect the ACTUS socket at the rear of the Core to the ACTUS socket at the rear of the User Interface.

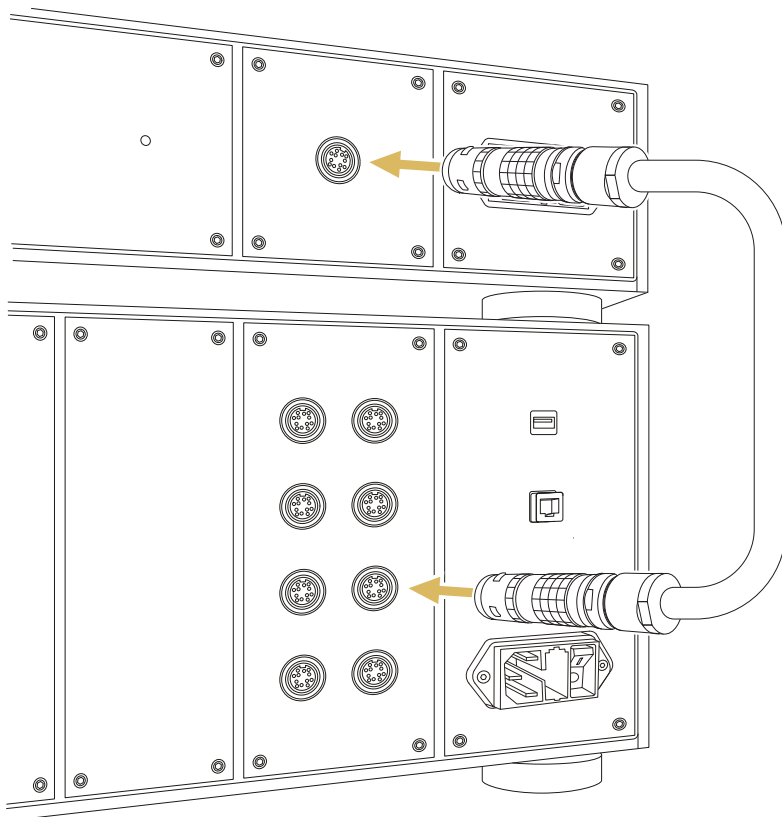

You need to attach the antenna to the rear of the User Interface.

- Using the supplied ACTUS cables, connect the ACTUS sockets at the rear of the Core to the ACTUS sockets at the rear of the left and right Mono DACs.

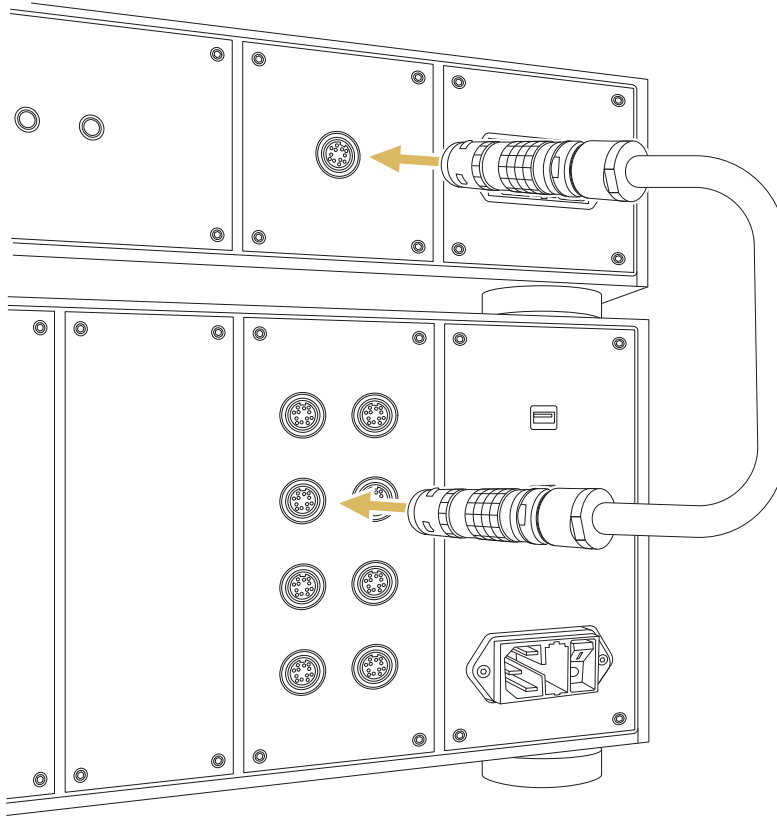

Connecting the Mono DACs to amplifiers

Use XLR or RCA cables to connect your left and right Mono DAC units to amplifiers. If the Mono DACs are connected directly to power amplifiers, the Varèse system can act as a preamplifier carrying out the system volume control.

The Mono DACs have two types of analogue output connections: balanced (XLR) and unbalanced (RCA). These outputs are independent, which allows you to connect each output to a different amplifier.



- Avoid connecting the unit's balanced output to an unbalanced input with an XLR cable. Such connection results in hissing noises, unstable levels, and a thin sound.
- If you are using the balanced outputs, perform the following steps:
 - At the rear of the left Mono DAC, connect the XLR cable to one of the BAL. LEFT sockets.
 - At the rear of the right Mono DAC, connect the XLR cable to one of the BAL. RIGHT sockets.

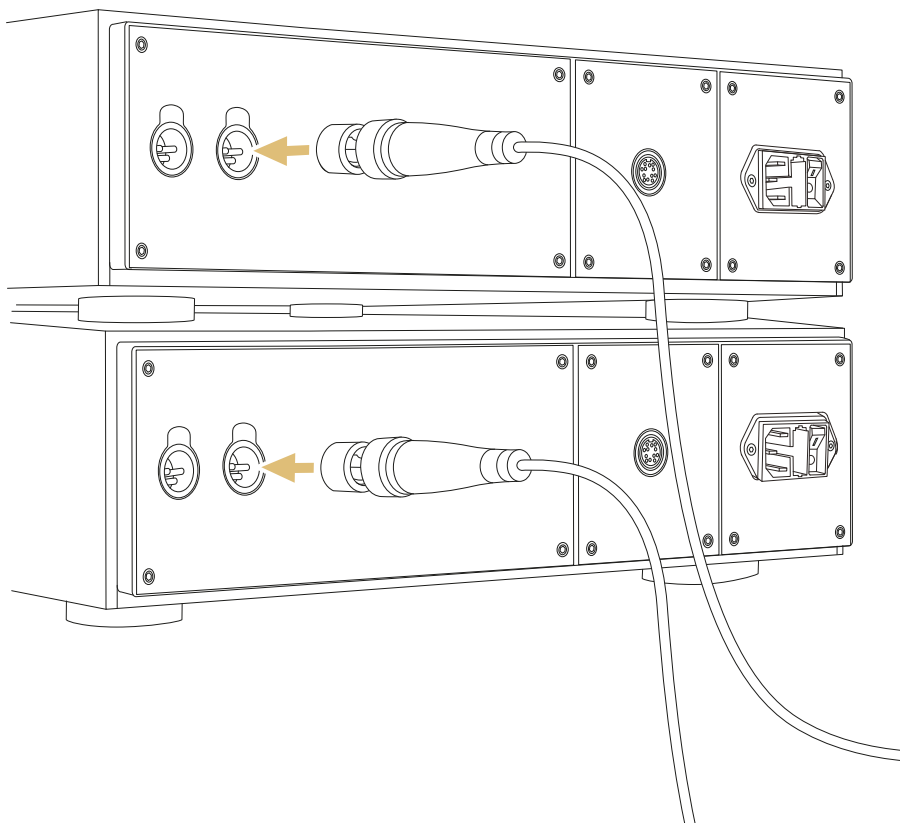

2. If you are using the unbalanced outputs, perform the following steps:

- At the rear of the left Mono DAC, connect the RCA cable to one of the UNBAL. LEFT sockets.
- At the rear of the right Mono DAC, connect the RCA cable to one of the UNBAL. RIGHT sockets.

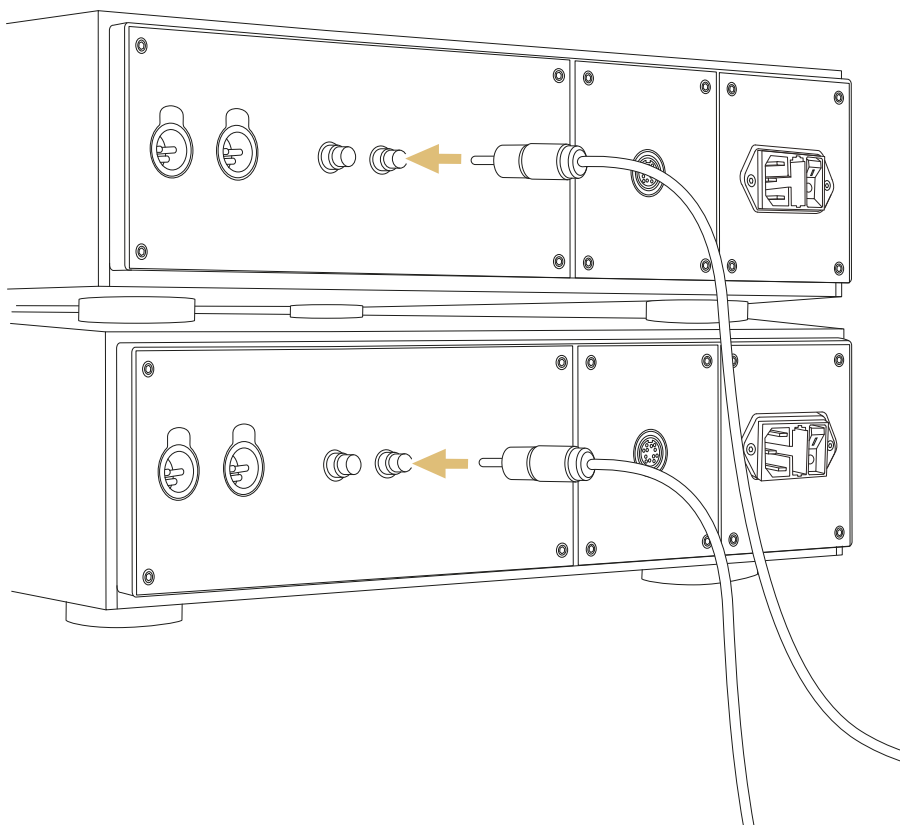

3. Connect the other end of the XLR or RCA cables to the amplifier or preamplifier.



The inputs on the amplifier or preamplifier may be labelled CD or AUX.

Refer to the user documentation for the amplifier or preamplifier.

Connecting the Digital I/O Module

Use the correct cables to connect the Digital I/O Module. The following connections are available.

Digital I/O Module connections	Connects to	Cable type
AES 1, AES 2, and AES 3	Digital audio sources with an AES output (including Dual AES)	110 ohm XLR cable
WCLK OUT	Digital audio sources with a compatible 75 ohm word clock input	75 ohm BNC cable
S/PDIF OUT	External devices, such as DACs, which can receive a $\leq 192k$ S/PDIF signal	75 ohm RCA cable
USB-B	USB output of a PC, Mac or server	USB-B cable
RS232	RS232 port of Rossini or Vivaldi Transport	“Null modem” RS232 cable

Connecting power and switching on

Use the supplied power cable to connect a Varèse unit to the power supply. With all units connected, you can safely switch on all your units.

1. At the rear of a unit, insert the power cable into the power socket, and then connect the power cable plug to a power supply.

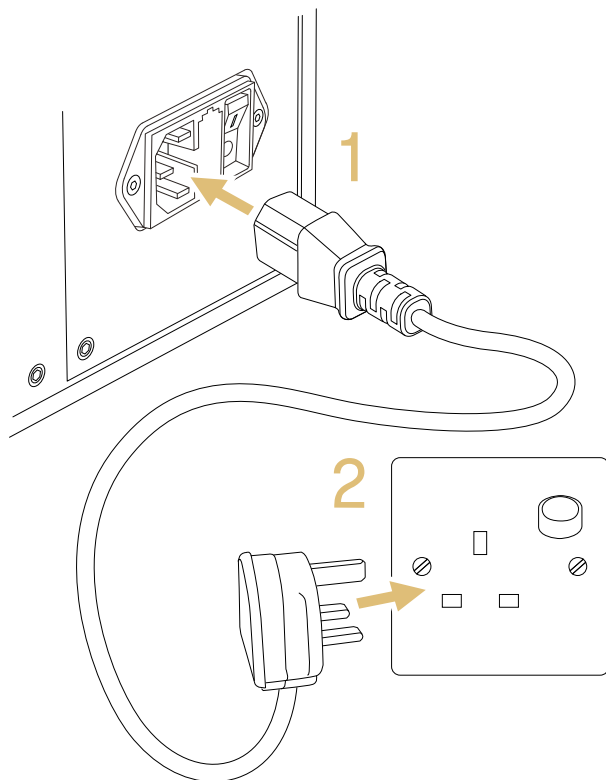

2. Next to the power socket on the unit, press the power rocker switch to the on position.

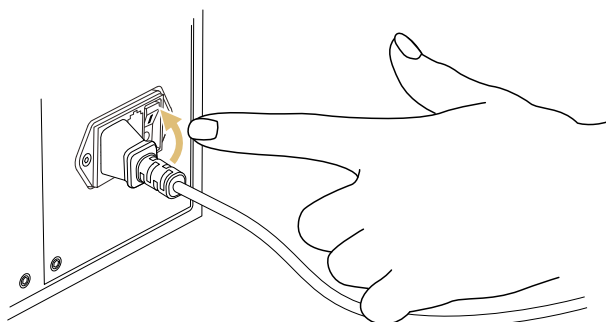

Connecting to your network

Connect your Core to a network to stream content from local sources, such as a music server on your network, or from internet services.

Before connecting the unit to your network, make sure your network router has spare Ethernet (RJ45) sockets.



To stream from internet services, your router must be connected to the internet.

For more information about configuring your network, contact your local service centre or a local IT expert.

1. At the rear of your Core, connect an Ethernet cable to the NETWORK socket.
2. Connect the other end of the Ethernet cable to your router.

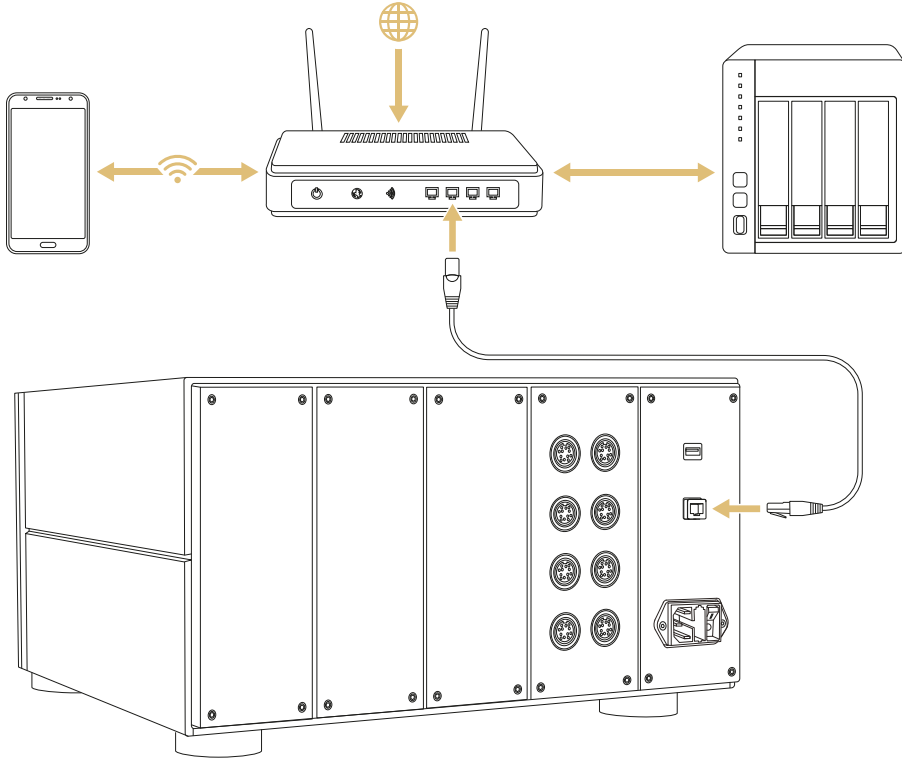

Maintenance

Charging the Remote Control's battery



CAUTION

Only charge the Remote Control battery with a USB-C cable and at an ambient temperature of 10 to 45 °C. Charging outside of this range may damage the battery and cause a hazard.

NOTICE

The Remote Control's battery is not replaceable. If there is a fault with the battery, return the Remote Control to an authorised service centre.

The Remote Control uses a rechargeable battery. When the battery level is low, a warning light appears on the Remote Control. The dCS Mosaic ACTUS app and the User Interface also display a low battery level notification.

1. Insert the USB-C cable into the Remote Control's charging port.

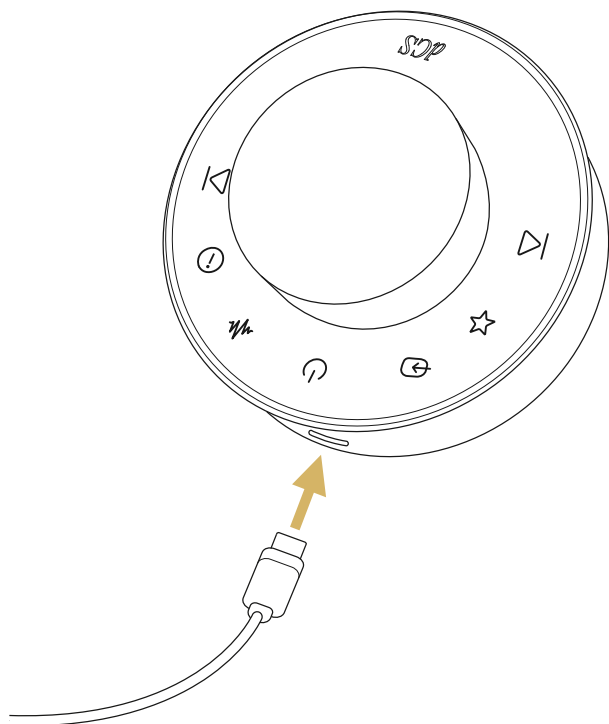

2. Connect the other end of the cable to the USB socket at the rear of the Core or a USB power adapter.
An amber light on the Remote Control indicates that it is charging.
3. When the light changes to green to indicate that charging is complete, remove the USB-C cable from the Remote Control's charging port.

Cleaning the unit

To remove fingerprints and loose dust, use a clean and dry lint-free cloth.

Replacing a blown mains fuse

There is a fuse within each unit's power inlet. If the fuse blows, you can replace it.

- If the fuse blows once, replace the fuse. There was a power surge.
- If the fuse blows repeatedly, contact your fulfilment centre to arrange repair.

 Fuse type 20 x 5 mm, T 1A L / 250 V.



WARNING

Replace the fuse with one of the same type and rating. If you use a fuse of a different type or rating, it may damage the unit and there is a risk of fire or electric shock. Using an incorrect fuse also invalidates the warranty.

1. Unplug the power cable from the unit.
2. Next to the power rocker switch, push the two tabs of the fuse holder towards the centre and pull out the fuse holder.

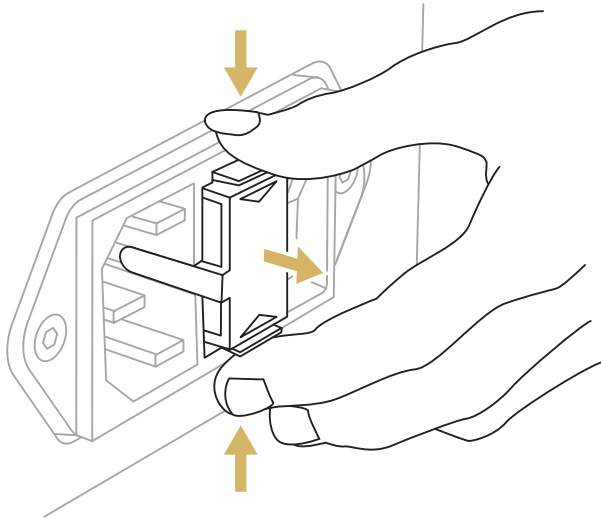

3. Remove the blown fuse from the lower position of the fuse holder.

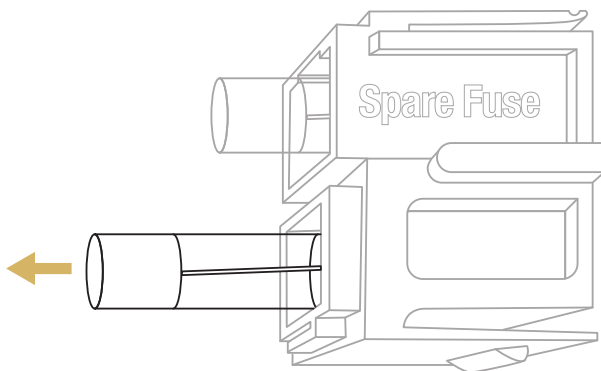

4. Replace the blown fuse with the spare fuse from the upper position.

5. With the writing on the fuse holder the correct way up, push the fuse holder back into the unit until you hear a click.

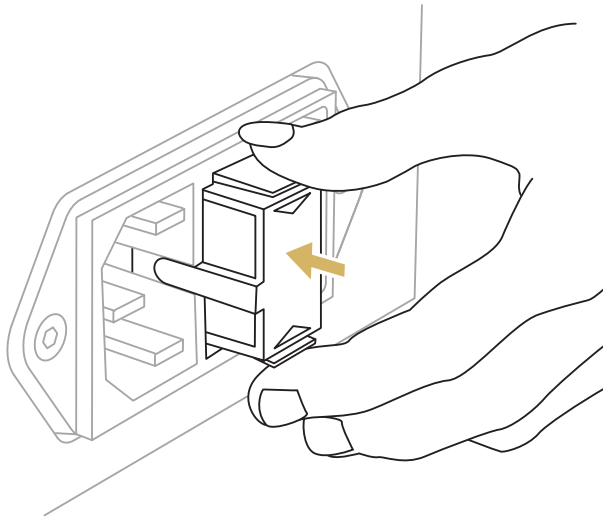

Specifications



These specifications are subject to change without notice.

Core specifications

Digital inputs	<ul style="list-style-type: none"> • 1x network interface on an Ethernet (RJ45) connector • 1x USB 2.0 client interface on type-A connector
Supported file formats	<ul style="list-style-type: none"> • FLAC • AIFF • WAV • ALAC • AAC • MP3 • DFF, DSF and DoP
Supported network protocols	<ul style="list-style-type: none"> • UPnP • Roon Ready • Apple AirPlay® • Google Cast
Supported streaming services	<ul style="list-style-type: none"> • Qobuz • Spotify • TIDAL • Deezer • Podcasts (via Airable)
ACTUS connectors	8x ACTUS
User interface	<ul style="list-style-type: none"> • Standby button • Status indicator • Power rocker switch (rear)
Power	<ul style="list-style-type: none"> • Class 1 mains product • Product must be earthed
Fuse type	20 x 5 mm, T 1A L / 250 V
Operating temperature	+10 to +45 °C
Product dimensions	244 mm (H) x 444 mm (W) x 425 mm (D)
Product weight	28.6 kg
Power requirements	85-130 V / 200-250 V, 50/60 Hz Power consumption: 40 W without optional modules fitted and 150 W with three expansion modules fitted.

User Interface specifications

Digital inputs	<ul style="list-style-type: none"> • 1x ACTUS • 1x BTLE antenna, for communicating with the Remote Control
Sources	<ul style="list-style-type: none"> • AirPlay stream, via ACTUS into the Varèse Core • Google Cast stream, via ACTUS into the Varèse Core
ACTUS connectors	1x ACTUS
User interface	<ul style="list-style-type: none"> • Standby button • Touchscreen; resolution 1920 x 358 px • Power rocker switch (rear)
Power	<ul style="list-style-type: none"> • Class 1 mains product • Product must be earthed
Fuse type	20 x 5 mm, T 1A L / 250 V
Operating temperature	+10 to +45 °C
Product dimensions	130 mm (H) x 444 mm (W) x 425 mm (D)
Product weight	12.3 kg
Power requirements	85-130 V / 200-250 V, 50/60 Hz Power consumption: 40 W

Mono DAC specifications

Converter type	dCS proprietary Ring DAC topology
ACTUS connections	1x ACTUS
Line outputs	<ul style="list-style-type: none"> • 2x 3-pin male XLR connectors • 2x RCA Phono connectors
User interface	<ul style="list-style-type: none"> • Standby button • Status indicator • Power rocker switch (rear)
Power	<ul style="list-style-type: none"> • Class 1 mains product • Product must be earthed
Fuse type	20 x 5 mm, T 1A L / 250 V
Operating temperature	+10 to +45 °C
Product dimensions	130 mm (H) x 444 mm (W) x 425 mm (D)
Product weight	16.6 kg
Power requirements	85-130 V / 200-250 V, 50/60 Hz Power consumption: 40 W

Clock specifications

Clock type	Grade 1 Master Clock.
Clock frequencies	44.1 kHz and 48 kHz
Clock accuracy	Within 1 ppm in an ambient temperature range of +5°C to +60°C
Word clock outputs	1x ACTUS
User interface	<ul style="list-style-type: none"> • Standby button • Status indicator • Power rocker switch (rear)
Power	<ul style="list-style-type: none"> • Class 1 mains product • Product must be earthed
Fuse type	20 x 5 mm, T 1A L / 250 V
Operating temperature	+10 to +45 °C
Product dimensions	130 mm (H) x 444 mm (W) x 425 mm (D)
Product weight	12.6 kg
Power requirements	85-130 V / 200-250 V, 50/60 Hz Power consumption: 40 W

Remote Control specifications

Range	< 10 m
Interface	USB-C
Product dimensions	115 mm (Ø) x 55 mm (H)
Product weight	0.5 kg
Power requirements	1 A

Help and support

If you need help using your Varèse, contact your fulfilment centre for assistance, quoting the serial number of your unit.

Manufactured by:

Data Conversion Systems Ltd.
Unit 1, Buckingway Business Park,
Anderson Road,
Swavesey,
Cambridgeshire,
CB24 4AE,
UK

www.dcsaudio.com

VARÈSE

dcsaudio.com | [@dCSonlythemusic](https://twitter.com/dCSonlythemusic) | info@dcsaudio.com

Data Conversion Systems Ltd.
Unit 1, Buckingway Business Park, Anderson Road,
Swavesey, Cambridge, CB24 4AE, UK



dCS
ONLY THE MUSIC